

**Exhibit 7.0.a**

**PJM System Impact Study**



***PJM Generator Interconnection  
Queue #Q68  
Kincaid-Pana (Christian County) 345kV  
(726MW Capacity)  
System Impact Study Report***

**December 2009**

**DOCS#: 542613v5**

## **Preface**

The intent of this System Impact Study is to determine a plan, with cost and construction time estimates, to connect the subject generation to the PJM network at a location specified by the Interconnection Customer. The Interconnection Customer may request the interconnection of generation as a capacity resource or as an energy-only resource. As a requirement for interconnection, the Interconnection Customer may be responsible for the cost of constructing: (1) Direct Connections, which are new facilities and/or facilities upgrades needed to connect the generator to the PJM network, and (2) Network Upgrades, which are facility additions, or upgrades to existing facilities, that are needed to maintain the reliability of the PJM system.

The PJM Reliability Planning Process utilizes PJM planning criteria, NERC Planning Standards, NERC Regional Council planning criteria, and the individual Transmission Owner FERC filed planning criteria. In all cases, PJM applies the most conservative of all applicable planning criteria when identifying reliability problems and determining the need for system upgrades on the PJM system. The application of the NERC Planning Standards is adapted to the specific needs of the PJM system.

In some instances a generator interconnection may not be responsible for 100% of the identified network upgrade cost because other transmission network uses, e.g. another generation interconnection, may also contribute to the need for the same network reinforcement.

After the System Impact Study Agreement is executed and prior to execution of the Interconnection Service Agreement, an Interconnection Customer may modify its project to reduce the electrical output (MW) (in the case of a Generation Interconnection Request) of the proposed project by up to the larger of 20 percent of the capability considered in the System Impact Study or 50 MW.

The System Impact Study estimates do not include the feasibility, cost, or time required to obtain property rights and permits for construction of the required facilities. The project developer is responsible for the right of way, real estate, and construction permit issues. For properties currently owned by Transmission Owners, the costs may be included in the study.

**General**

Christian County Generation, LLC. (CCG) proposes to install a 726 MW capacity Integrated Gasification Combined Cycle 2x1 generating facility comprised of two combustion turbine generators and one steam turbine generator to be located in Christian County, Illinois. This project is number Q68 in the PJM Generator Interconnection queue. The projected in-service date is scheduled for December 31, 2013.

**Facilities to Accommodate the Interconnection**

**Figure #1: Proposed Interconnection**

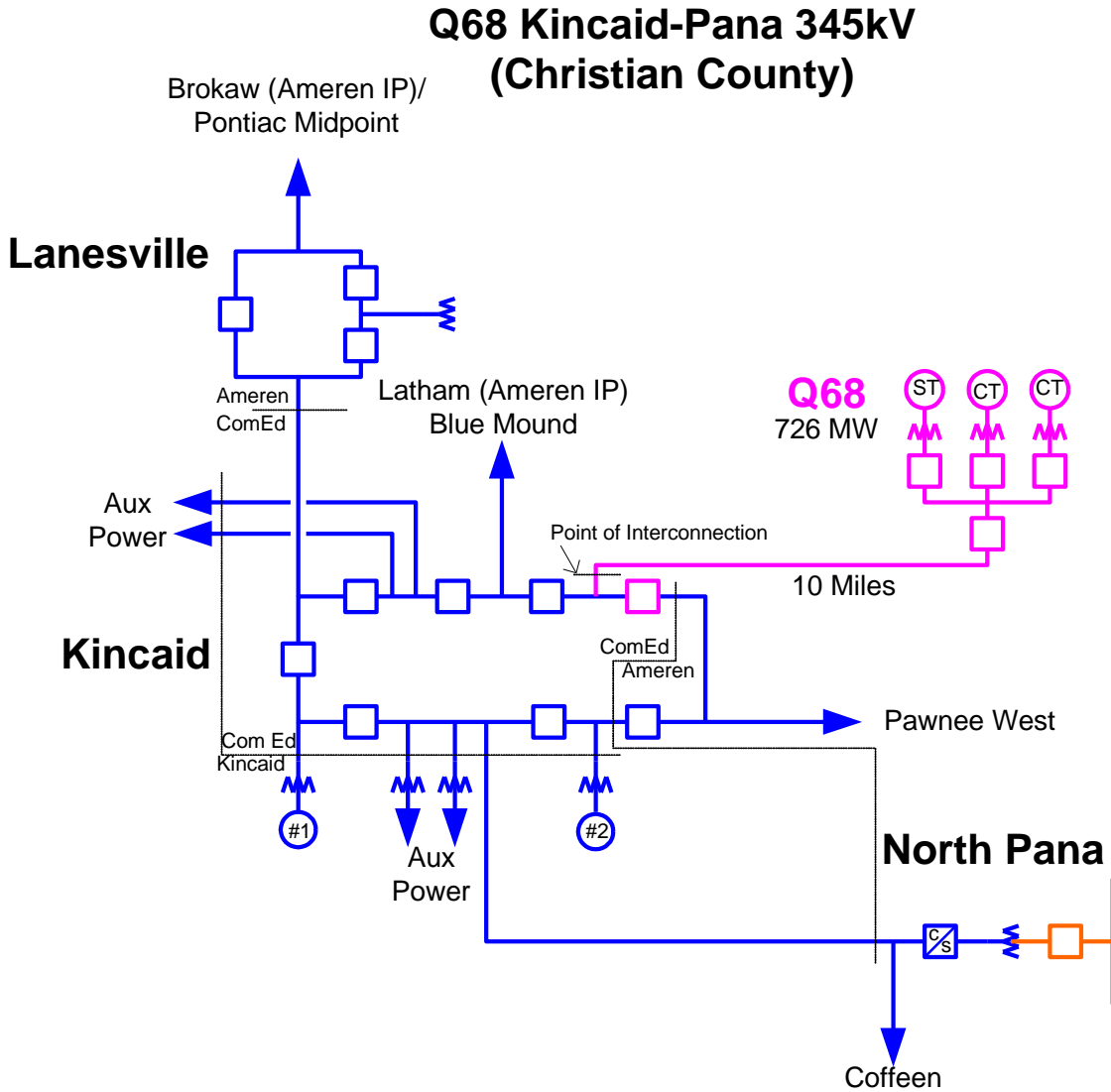

**ComEd Scope of Direct Connection Work**

Direct Connection Cost Estimate

For the direct connection into Kincaid Station switchyard the estimate for the work to be done by ComEd is described below:

Qty	Item Description	Estimated Cost
1	One new breaker bay position- includes 345 kV Circuit Breaker, foundation, wiring, conduit, CCVT, relaying and Disconnects.	\$ 1,541,000
1	Dead End Structure	\$ 429,000
1	Motor Operated Disconnect Switch	\$ 180,000
1	Optical Metering	\$ 200,000
1	SCADA system upgrade	\$ 15,000
1	Bus Relays and Panel	\$ 30,000
	Engineering and Project Management	\$ 200,000
	<b>Total</b>	<b>\$ 2,595,000</b>

Installation of new breaker BT 7-10 is PJM Network Upgrade #n1480. See New System Reinforcements for The Estimated Time to complete the substation work is 18-24 months

This assumes CCG is responsible for designing and installing the generator lead to the fence line of the Kincaid substation.

**Network Impacts**

The Queue Project #Q68 was studied as a 726MW capacity injection at Kincaid 345kV substation in the ComEd area. Project #Q68 was evaluated for compliance with reliability criteria for summer peak conditions in 2011. The analysis of Q68 was done under the assumption that MISO Queue Project #G661 is mutually exclusive and, therefore, not active for this study. Potential network impacts were as follows:

**Generator Deliverability**

*(Single or N-1 contingencies for the Capacity portion only of the interconnection)*

No problems were identified.

**Multiple Facility Contingency**

*(Double Circuit Tower Line, Line with Failed Breaker and Bus Fault contingencies for the full energy output)*

No problems were identified.

**Short Circuit**

*(Summary of impacted circuit breakers)*

No problems were identified.

**Contribution to Previously Identified Overloads**

*(This project contributes to the following contingency overloads, i.e. "Network Impacts", identified for earlier generation or transmission interconnection projects in the PJM Queue)*

1. The Keystone-Juniata 500kV line (from bus 11 to bus 98127 ckt 1 ) loads from 107.11% to 108.93% (AC power flow) of its emergency rating (3700MVA) for the line fault stuck breaker outage (PJM53), the failure of the breaker to open at Conemaugh for a fault on the Keystone-Conemaugh 500kV circuit. This project contributes approximately 79.3 MW to the thermal violation. See Contribution to

Previously Identified System Reinforcements section below for costs and upgrades associated with this violation.

2. The Kammer – West Bellaire 345kV line (from bus 22609 to bus 22624 ckt 1) loads from 104.44% to 107.10% (AC power flow) of its emergency rating (1304MVA) for the line fault stuck breaker outage (AEP\_LINE\_FB67). This project contributes approximately 40.86 MW to cause this thermal violation. See Contribution to Previously Identified System Reinforcements section below for costs and upgrades associated with this violation.

### **Contribution to Previously Identified Overloads Caused By MISO Generator Interconnection Projects**

*(This project contributes to the following contingency overloads, i.e. "Network Impacts", identified for earlier generation or transmission interconnection projects in the MISO Queue with additional contribution to the overload by PJM Queue projects.)*

None

### **Stability Requirements**

The scenarios included in this study are consistent with the planning criteria of ComEd's Transmission Planning department and include the study of 3-phase faults cleared in primary time, breaker failures, maintenance outages, and tower outages.

Table 1 summarizes the required changes and upgrades resulting from the installation of the Q68 project at Station 21 Kincaid. Table 1 also shows the type of scenario requiring the change. When a change is required by more than one scenario, only the earliest occurring scenario is shown in the table.

Table 1: Summary of Breaker Replacements and Relay Changes

<b>Upgrade or Change</b>	<b>Type of Scenario</b>
Replace BT1-3	Breaker Failure
Replace BT3-5	Breaker Failure
Replace BT5-7	Breaker Failure

Additional information can be found in the ComEd report entitled "Generator Transient Stability Study for Station 21 Kincaid", PJM Document (DOCS) Number 548231.

### **Reactive Power Requirements**

The Interconnection Customer shall design its Customer Facility with the ability to maintain a power factor of at least 0.95 leading to 0.90 lagging measured at the generator's terminals.

### **New System Reinforcements**

*(Upgrades required to mitigate reliability criteria violations, i.e. Network Impacts, initially caused by the addition of this project generation)*

There are three 345 kV breakers, BT1-3, BT3-5, and BT5-7(PJM Network Upgrades #n1476, #n1477 and n#1478 respectively), at Station 21 Kincaid that have been identified for replacement to maintain system stability. The estimated cost for replacing three breakers is \$2,289,000. Additional details can be found in the stability analysis report.

### **Contribution to Previously Identified System Reinforcements**

*(Overloads initially caused by prior Queue positions with additional contribution to overloading by this project. This project may have a % allocation cost responsibility which will be calculated and reported for the Impact Study.)*

1. **Keystone – Juniata 500 kV Upgrade:** The overload on the Keystone-Juniata 500kV circuit can be alleviated by installing a fourth breaker and one-half bay at Conemaugh 500kV substation to which the Keystone-Conemaugh line will be moved, eliminating the stuck breaker concern. This change will require the addition of two breakers and four switches. The estimated cost of this upgrade is **\$6,341,500** (PJM Network Upgrade #n1101).

<b>Queue</b>	<b>MW Contribution</b>	<b>% of Cost</b>	<b>Cost (\$K)</b>
P58	4.07	2.12%	134.31
Q01	55.4	28.83%	1828.17
Q43	53.4	27.79%	1762.17
Q68	79.3	41.27%	2616.86

2. The Kammer-West Bellaire overload can be alleviated by replacing the risers on the Kammer terminal of the line. This change will raise the emergency rating of the line to 1413MVA. The cost for this upgrade is **\$210,300** (PJM Network Upgrade #n0587). The cost of the reinforcement will be shared as shown in the table below.

<b>Queue</b>	<b>MW Contribution</b>	<b>% of Cost</b>	<b>Cost (\$K)</b>
Q43	19.04	31.81%	66.90
Q68	40.82	68.19%	143.40

### **MISO Potential Issues**

Impacts on the MISO member transmission systems are not finalized in this analysis, but they will be included in the Facilities Study, which may reveal upgrades needed in the MISO system not identified in this Impact Study.

The following table lists potential overloads following single contingencies and their mitigation for the MISO footprint:

FROM BUS#	NAME	BASKV	AREA	TO BUS#	NAME	BAS KV	AREA	CKT	LOADING	RATING	PERCENT	REQUIRED AMPS	EXISTING AMPS	EQUIPMENT	NEW AMPS	UPGRADE DESC	COST	Comment
348910	4LINCOLN JCT	138	357	349659	4KICKAPOO	138	357	1	215.8	183	117.9	903	767	5.22 miles of 477 kcmil ACSR 18/1	1278	Reconductor with 556 ACSS	\$2,110,000	
349641	4TAZEWELL	138	357	349675	4MASON	138	357	1	343.7	254	135.3	1438	1063	Disconnect Switch, Circuit Switcher, Relay, 0.2 miles of 795 kcmil ACSR 45/7, 17.83 miles of 556.6 kcmil SSAC 26/7, 3.67 miles of ACAR 24/13 (927)	1615	Reconductor with 795 ACSS	\$9,000,000	If structures cannot support new conductor the cost may be as high as \$27,650,000
349657	4HOLLAND	138	357	349659	4KICKAPOO	138	357	1	131.8	125	105.4	551	500	CT	600		\$0	
349657	4HOLLAND	138	357	349675	4MASON	138	357	1	328.8	255	128.9	1376	1065	2 Disconnect Switches, Circuit Switcher, 0.2 miles of 795 kcmil ACSR 45/7, 10.83 miles of 556.5 kcmil SSAC 26/7	1615	Reconductor with 795 ACSS	\$6,400,000	
349700	7LANSVLAM	345	357	349701	4LANVL	138	357	1	373.8	308	121.4	1564	1289	Transformer, CT	2343	New 560 MVA Transformer	\$4,500,000	
349641	4TAZEWELL	138	357	349675	4MASON	138	357	1	256.1	254	100.8	1071	1063	Disconnect Switch, Circuit Switcher, Relay, 0.2 miles of 795 kcmil ACSR 45/7, 17.83 miles of 556.6 kcmil SSAC 26/7, 3.67 miles of ACAR 24/13 (927)	1615	Same as above	Same as above	Same as above

### **Potential Congestion due to Local Energy Deliverability**

*(PJM also studied the delivery of the energy portion of the surrounding generation. Any potential problems identified below are likely to result in operational restrictions to the project under study. The developer can proceed with Network Upgrades to eliminate the operational restriction at their discretion by submitting a Transmission Interconnection Request. Note: Only the most severely overloaded conditions are listed below. There is no guarantee of full deliverability for this project by fixing only the conditions listed in this section. With a Transmission Interconnection Request, a subsequent analysis will be performed which looks at all overload conditions associated with the identified overloaded element(s). As a result of the aggregate energy resources in the area, the following violations were identified:*

1. The ComEd-owned Loretto (#O51/Cayuga Ridge South Wind Farm) to Wilton Center 345kV line 11212 loads from 117.24% to 131.95% of its emergency rating (1280MVA) for the outage of 345kV line 18814 (Odell/#O24/Chenoa Wind Farm to Dresden). This project contributes approximately 211.4 MW to this congestion. Several MISO Queue projects ahead of #Q68 contribute approximately 228.65 MW (17.86%) to cause this overload.
2. The ComEd-owned Pontiac to Loretto (#O51/Cayuga Ridge South Wind Farm) 345kV line 8012 loads from 105.67% to 120.75% of its emergency rating (1234MVA) for the outage of 345kV line 18814 (Odell/#O24/Chenoa Wind Farm to Dresden). This project contributes approximately 186.16 MW to this congestion. Several MISO Queue projects ahead of #Q68 contribute approximately 228.60 MW (18.53%) to cause this overload.