

## **Exhibit 5.5**

### **Siemens Operations and Maintenance Reliability Availability Maintenance Analysis**



---

## **Operations and Maintenance Reliability Availability Maintenance Analysis (RAM) Taylorville Energy Center**



Statements made in this document that may predict, forecast, indicate or imply future results, performance or achievements, and may contain “believe”, “anticipate”, “expect”, “estimate”, “project”, “will be”, “will continue”, “will likely result”, “plan”, or words or phrases of similar meaning, involves risks, uncertainties or other factors which may cause actual results to differ materially from the future results, performance or achievement expressed or implied by the statements. These statements are based on Siemens’ belief and assumptions.

Siemens has utilized what it considered to be current information provided on the Taylorville Energy Center and internal and industry data to provide this report. Although we believe that the estimates and projections reflected in this document are reasonable, our expectations may prove to be incorrect. Important factors that could cause actual results to differ materially from the results and events anticipated or implied by such forward-looking statements include (but are not limited to):

Plant detailed design may be different

Equipment specified may be different

Automation and controls may be different

As discussed above, this list of risk factors is not comprehensive.

Accordingly, the information, analyses, conclusions, recommendations and descriptions in this document: (i) are provided for information only, (ii) are based on Siemens' experience and judgment with respect to the Siemens' equipment and/or services to which this pertains, (iii) should not be considered as all inclusive or covering all contingencies, and (iv) ARE FURNISHED WITHOUT ANY WARRANTY WHATSOEVER, WHETHER EXPRESS OR IMPLIED, OF FITNESS FOR PURPOSE, MERCHANTABILITY, FROM COURSE OF DEALING OR USAGE OF TRADE, AS TO ADEQUACY, ACCURACY, COMPLETENESS OR USEFULNESS, OR OTHERWISE.

## Ram Analysis

The RAM analysis tool is a Siemens AG proprietary gasification plant configuration and RAM calculation tool. It is part of Siemens Gasification R&D development effort and is designed to calculate the equivalent plant Syngas output based on plant configuration, typical process redundancies, component reliability and plant maintenance schedules.

Reliability is defined as the ability of a plant, system or component to perform its required functions under stated conditions for a specified period of time. Reliability does not consider the time in which the system can not perform its functions because of scheduled maintenance. Availability is the ratio of (a) the total time a functional/ reliable system is capable of being used during a given interval to (b) the length of the interval. This ratio includes the time the system is not available because of forced downtime and scheduled maintenance.

The plant reliability is calculated with the help of Failure Mode Effect Analysis (FMEA), Markov models, operation and maintenance experience, published component reliability and system information.

The reliability of a gasification system strongly depends on the quality of the detailed design, the controls philosophy and the selection of the most reliable components. This RAM analysis is not based on a specific detailed design but it is based on the assumption that the detailed design is guided by prudent design principles and component selection. An implemented Monte Carlo simulation of the RAM calculation improves the quality of RAM tool results. We regard this RAM simulation software as an important tool to assess the design quality in regards to RAM.

The maintenance plans used in the model reflect generic data with some maintenance assumptions obtained from Tenaska for scheduled maintenance and reflects typical component manufacturer information, system and maintenance experience. Availability improvements can be achieved when the final design is complete. The annual maintenance plans will have to be adjusted to the actual systems design (e.g.: train redundancy) and to the requirements of plant components selected. The analysis is based on some assumptions of efficiency in the completion of any potential scheduled maintenance during the forced outages times. The following assumptions are being used:

- The planned gasifier burner and coal island inspections are managed during unplanned outages.
- The ASU planned maintenance cycles will be scheduled within the overall facility shutdown on 3 year intervals.

The RAM tool is designed to calculate the reliability factor and the equivalent availability of the stable system when it is fully commissioned. During the first years of operation the plant stability must be improved by debugging and system improvements. This tool can not reflect on the quality of the process design, plant construction & commissioning or the O&M team. Therefore a learning and improvement period has to be applied with reduced plant reliability for the first years of plant operation. Past experience from the startup of IGCC plants indicate that a learning curve can be expected. Compared to first generation IGCC plants (Figure 1), second

generation IGCC data (Figure 2) show an improvement in the learning curve. This second generation plant is a heavy liquid IGCC plant located in Italy. Since Taylorville is a coal plant an improvement between the early coal IGCC and the second generation Oil fired IGCC could be expected. For the Taylorville Energy Center in Taylorville, IL, the plant availability for the first and second year of operation is assumed to be in the range of 55-65% for the first and 75-85% for the second year of operation. The following years are calculated based on the calculated system reliability and scheduled maintenance requirements.

Siemens Energy Service has developed close relationships with the following leading component and system suppliers to cooperate during the RAM tool development phase and to validate the results of the RAM calculation tools.

Siemens Fuel Gasification, D	Coal Gasification and Syngas scrubbing
Johnson Matthey, UK	CO-Shift, COS Hydrolysis, Methanization
Claudius Peters, D	Coal Milling and Drying
Siemens Energy, D	ASU Compressors
Red Mountain Energy	ASU plant
Linde, D	ASU, AGR
Williams Crusher, US	Coal Milling and drying and conveying
Siemens Energy	Controls

**Plant Layout**

The RAM model for this project is based on the following assumed plant layout:

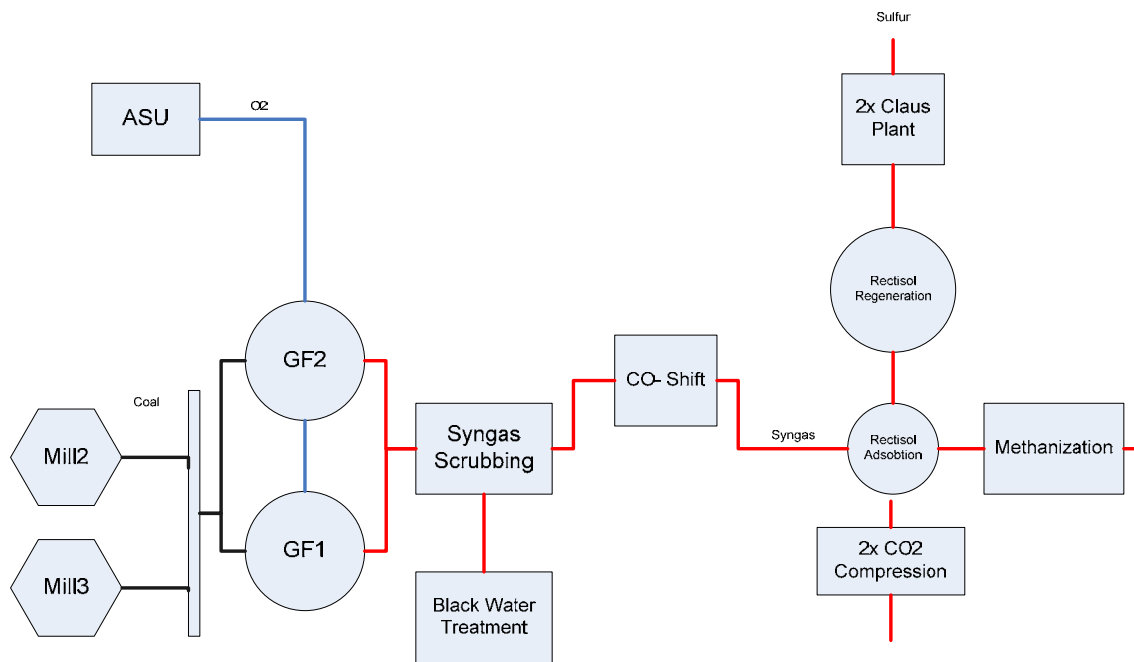

**Plant Configuration**

<b>Module:</b>	<b>Included in RAM calculation:</b>
Gasification	Yes
Milling	Yes
ASU	Yes
COS_Hydrolysis	No
CO-Shift	Yes
Methanation	Yes
Rectisol	Yes
Claus Plant	Yes

**Detail Plant Description (Input)**

**Gasification Systems**

Gasifiers	2
Blackwater systems	1
Capacity of Blackwatersystems (Gasifiers)	2
Necessary number of Gasifiers at 100% for Total Output of 100% of the Gasification System	2

**Milling and Drying**

Number of Silos Pulverized Coal	2
Number of Coal Mills	2
Necessary Mills Working per silo:	1
Capacity of Silo Pulverized Coal (h)	8
Capacity of Silo Raw Coal (h)	12

**ASU**

Number of ASU Modules for 100% capacity	1
Oxygen Storage	24h

**CO Shift**

Number of Shift Modules	1
-------------------------	---

**COS Hydrolysis**

Number of Hydrolysis Modules	not applicable
------------------------------	----------------

**AGR Rectisol**

Number of Absorption Lines	1
Number of Regeneration Lines	1
Capacity of a	1

Regeneration Line

**Sulfur Treatment Plant**

Number of Claus Plants	2
Number of Tail Gas Treatment	2
Capacity of TGT	1
<b>Methanation</b>	
Number of Methanization Modules**	1

**RAM Calculation Results for the Gasification Plant**

Observation Period (years)	12
Year 1	55-65%*
Year 2	75-85%*
Year 3	86.0%
Year 4	86.0%
Year 5	86.0%
Year 6	85.1%
Year 7	86.1%
Year 8	86.0%
Year 9	80.3%
Year 10	85.9%
Year 11	85.9%
Year 12	85.2%

Average estimated annual equivalent available output over 10 years after shake down period.  
(Includes forced and scheduled outages)

**85.2 % of Total Output**

\*Learning curve and system improvement period

**IGCC Availability History**  
*excludes operation on back-up fuel*

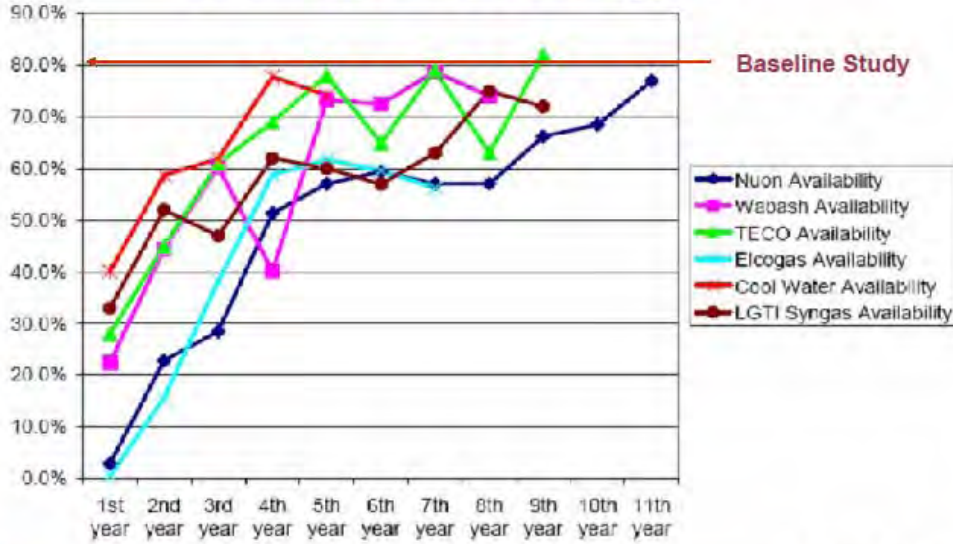

Source: EPRI

Figure 1



## IGCC AVAILABILITY

**Plant Start-up in 2000. IGCC availability has increased due to the technical improvements and to the O&M management optimisation.**

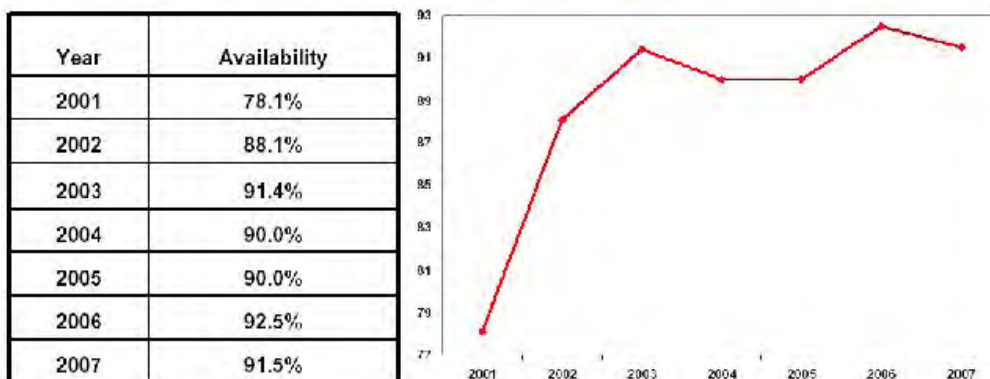

NOTE: Plant availability includes also the scheduled shutdown

**Figure 2**